

## Hex Head Concrete Bolt

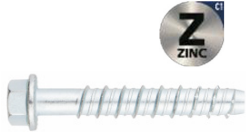

## Pan Head Concrete Bolt



## Male Rod Hanger

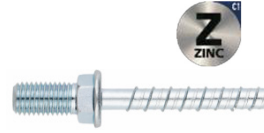

## Female Rod Hanger

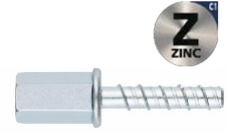

## Technical Datasheet

- Pilot hole in concrete needed, thread is created by the anchor during the installation process.
- Use for high loads.
- Assessed for 2 installation depths and 3 for Ø10.
- Use in cracked and non-cracked concrete.
- Comply with guideline VdS CEA 4001:2021-01(07) "Guidelines for sprinklers systems. Planning and installation".
- Suitable when reduced edge distances or spacing required.
- Qualified for static and quasi-static.
- Easy installation.
- Installation through the fixture.
- Reusable.
- Removable, leaving concrete surface flat.
- Variety of lengths and sizes, assembly flexibility.
- VdS available from Ø6 to Ø18.

## Application

- Structural fixings in cracked and uncracked concrete subject to dry internal conditions.
- Glazing, windows and storefronts
- Racking and shelving
- Attaching railings, handrails and ledgers
- Fixings wood structures in concrete

## Assessments



## Maximum loads recommended for cracked and uncracked concrete (kg)

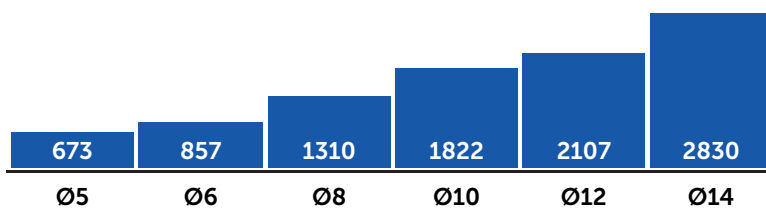

## Base material



## Size range

Ø6 - Ø8







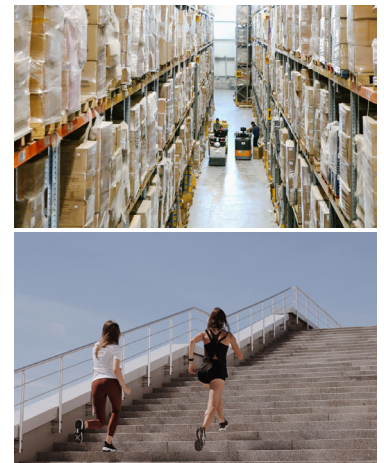

## Drill condition



## Kora in use



## Range

Code	Sizes	Photo	Description	Material	Covering
B431-322	Ø6 x 40		Hexagonal head with flange screw anchor	Carbon steel, zinc plated coating $\geq 5 \mu\text{m}$	
B431-325	Ø6 x 50				
B431-332	Ø6 x 60				
B461-432	Ø8 x 60				
B465-315	Ø6 x 40		Pan head screw anchor	Carbon steel, ATLANTIS coating	
R642-415	Ø6 x 35 M8 - M10		Rod hanger internal thread screw anchor	Carbon steel, zinc plated coating $\geq 5 \mu\text{m}$	
R642-515	Ø6 x 55 M8 - M10				
R642-209	Ø6 x 35 M8		Hexagonal head with flange and with external thread screw anchor	Carbon steel, zinc plated coating $\geq 5 \mu\text{m}$	

## Installation data

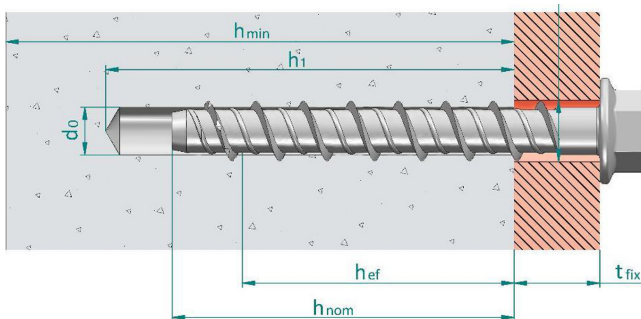

**d0:** Nominal diameter of drill bit  
**df:** Fixture clearance hole diameter  
**hef:** Effective anchorage depth  
**h1:** Depth of drilled hole  
**hnom:** Overall fastener embedment depth in the concrete  
**hmin:** Minimum thickness of concrete member  
**tfix:** Fixture thickness

Type	B431-322, B431-332, B461-432, B465-315, R642-209, R642-415, R642-515
Diameter (mm)	6
d1: Threaded outer diameter (mm)	7,35
d2: Core diameter (mm)	5,75
ds: Shaft diameter (mm)	5,95
dk: Diameter of integrated washer (mm)	14,00

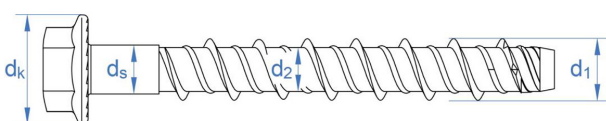

## Seismic load assessment

Product	Size	ETA Approved	C1
B431-322	Ø6 x 40	✓	
B431-325	Ø6 x 50	✓	✓
B431-332	Ø6 x 60	✓	✓
B461-432	Ø8 x 60	✓	✓
B465-315	Ø6 x 40	✓	
R642-415	Ø6 x 35 M8 - M10	✓	
R642-515	Ø6 x 55 M8 - M10	✓	✓
R642-209	Ø6 x 35 M8	✓	

## Installation parameters

General installation parameters									Standard installation depth (Hef, std)								Reduced installation depth (Hef, red)																
Product	Size	ETA Approved	Drill bit diameter	Fixture clearance hole	Spanner	Maximum torque	Minimum allowable spacing	Minimum allowable edge distance	Minimum concrete thickness	Depth of drill hole	Installation depth	Effective anchorage depth	Thickness of fixture	Critical spacing ( concrete cone)	Critical edge distance (cone)	Critical spacing (splitting)	Critical edge distance (splitting)	Minimum concrete thickness	Depth of drill hole	Installation depth	Effective anchorage depth	Thickness of fixture	Critical spacing ( concrete cone)	Critical edge distance (cone)	Critical spacing (splitting)	Critical edge distance (splitting)							
B431-322	Ø6 x 40	✓	6	9	SW10	10	35	35	-	-	-	-	-	-	-	-	-	100	45	35	26,0	5	78	39	90	45							
B431-325	Ø6 x 50	✓							-	-	-	-	-	-	-	-	-					-					-	-	-	-	15		
B431-332	Ø6 x 60	✓							100	65	55	43,0	5	129	65	170	85					25											
B461-432	Ø8 x 60	✓	8	12	SW13	20	35	35	-	-	-	-	-	-	-	-	-	100	60	50	37,5	10	113	57	130	65							
B465-315	Ø6 x 40	✓	6	-	SW13	10	35	35	-	-	-	-	-	-	-	-	-					45					35	26,0	5	78	39	90	45
R642-415	Ø6 x 35 M8 - M10	✓							-	-	-	-	-	-	-	-	-					-							-				
R642-515	Ø6 x 55 M8 - M10	✓							100	65	55	43,0	-	129	65	170	85	-	-	-	-	-	-										
R642-209	Ø6 x 35 M8	✓	-	-	-	-	-	-	-	-	-	-	-	-	-	-	-	100	65	55	26,0	-	78	39	90	45							

## Resistances

Resistances in concrete class C20/25 for an isolated anchor without spacing or concrete edge distance effects are indicated in the following table:

Values in **green** show Steel failure, **blue** values concrete failure and other indicate pull out failure.  
1 kN ≈ 100 kg

## Characteristics resistance (structural application) [kN]

General parameters			Non-cracked concrete				Cracked concrete			
Product	Size	ETA Approved	Tension N <sub>rk, ucr</sub>		Shear V <sub>rk, ucr</sub>		Tension N <sub>rk, ucr</sub>		Shear V <sub>rk, ucr</sub>	
			(hef, std)	(hef, red)	(hef, std)	(hef, red)	(hef, std)	(hef, red)	(hef, std)	(hef, red)
B431-322	Ø6 x 40	✓	-	5,00	-	12,53	-	4,57	-	9,36
B431-325	Ø6 x 50	✓	-	5,00	-	12,53	-	4,57	-	9,36
B431-332	Ø6 x 60	✓	13,87	5,00	12,53	12,53	9,71	4,57	11,17	9,36
B461-432	Ø8 x 60	✓	-	11,30	-	19,57	-	7,91	-	14,23
B465-315	Ø6 x 40	✓	-	5,00	-	-	-	4,57	-	-
R642-415	Ø6 x 35 M8 - M10	✓	-	5,00	-	-	-	4,57	-	-
R642-515	Ø6 x 55 M8 - M10	✓	13,87	-	-	-	9,71	-	-	-
R642-209	Ø6 x 35 M8	✓	-	5,00	-	-	-	4,57	-	-

## Design resistances (structural application) [kN]

General parameters			Non-cracked concrete				Cracked concrete			
Product	Size	ETA Approved	Tension N <sub>rk, ucr</sub>		Shear V <sub>rk, ucr</sub>		Tension N <sub>rk, ucr</sub>		Shear V <sub>rk, ucr</sub>	
			(hef, std)	(hef, red)	(hef, std)	(hef, red)	(hef, std)	(hef, red)	(hef, std)	(hef, red)
B431-322	Ø6 x 40	✓	-	2,78	-	8,35	-	2,54	-	6,24
B431-325	Ø6 x 50	✓	-	2,78	-	8,35	-	2,54	-	6,24
B431-332	Ø6 x 60	✓	9,25	2,78	8,35	8,35	6,47	2,54	7,44	6,24
B461-432	Ø8 x 60	✓	-	6,28	-	13,05	-	4,39	-	9,49
B465-315	Ø6 x 40	✓	-	2,78	-	8,35	-	2,54	-	6,24
R642-415	Ø6 x 35 M8 - M10	✓	-	2,78	-	-	-	2,65	-	-
R642-515	Ø6 x 55 M8 - M10	✓	9,25	-	-	-	6,47	-	-	-
R642-209	Ø6 x 35 M8	✓	-	2,78	-	-	-	2,54	-	-

## Maximum Loads Recommended (structural application) [kN] (with $\gamma_F = 1.4$ )

General parameters			Non-cracked concrete				Cracked concrete			
Product	Size	ETA Approved	Tension N <sub>rk, ucr</sub>		Shear V <sub>rk, ucr</sub>		Tension N <sub>rk, ucr</sub>		Shear V <sub>rk, ucr</sub>	
			(hef, std)	(hef, red)	(hef, std)	(hef, red)	(hef, std)	(hef, red)	(hef, std)	(hef, red)
B431-322	Ø6 x 40	✓	-	1,98	-	5,97	-	1,81	-	4,46
B431-325	Ø6 x 50	✓	-	1,98	-	5,97	-	1,81	-	4,46
B431-332	Ø6 x 60	✓	6,61	1,98	5,97	5,97	4,62	1,81	5,32	4,46
B461-432	Ø8 x 60	✓	-	4,48	-	9,32	-	3,14	-	6,78
B465-315	Ø6 x 40	✓	-	1,98	-	5,97	-	1,81	-	4,46
R642-415	Ø6 x 35 M8 - M10	✓	-	1,98	-	-	-	1,81	-	-
R642-515	Ø6 x 55 M8 - M10	✓	6,61	-	-	-	4,62	-	-	-
R642-209	Ø6 x 35 M8	✓	-	1,98	-	-	-	1,81	-	-

## Official documentation

---

- European assessment ETA 20/0046 for Installation in cracked and non-cracked concrete according to guideline EAD 330232-00-0601, Option 1, from Ø6 to Ø18.
- European assessment ETA 20/0494 for use in concrete and prestressed hollow core slabs for redundant non-structural systems according to guideline EAD 330747-00-0601 from Ø5 to Ø6.
- Declaration of performance DoP THE.
- VdS certificate CEA 4001:2021-01(07) Guidelines for sprinklers systems. Planning and installation for applications of water extinguishing systems on concrete elements from Ø6 to Ø18.